

ANTENNA LIST			
ELEV	QTY	ANTENNA	COAX
60'	1	10 SQ FT EPA	(6) 3/8"

THE TABULATED ALLOWABLE EFFECTIVE PROJECTED AREAS (EPA) REPRESENT THE SUMMATION OF THE PROJECTED AREAS OF ALL ANTENNAS, MOUNTS, AND APPURTENANCES MULTIPLIED BY APPROPRIATE DRAG FACTORS. THE ALLOWABLE PROJECTED AREAS ARE ASSUMED TO BE PLACED SYMMETRICALLY ON THE STRUCTURE. LOWER EPA VALUES MAY APPLY FOR OTHER EPA ARRANGEMENTS.

TOWER MATERIAL LIST					
ELEVATION	SECTION #	LEGS	DIAGONALS	HORIZONTALS	BAY SPACING
50' TO 60'	1810 S-M	2.000" OD x 0.134" THK	1/2" SOLID ROD	1/2" SOLID ROD	6 BAYS @ 1'-5 1/4"
40' TO 50'	1810 S-M	2.000" OD x 0.134" THK	1/2" SOLID ROD	1/2" SOLID ROD	6 BAYS @ 1'-5 1/4"
30' TO 40'	1810 S-M	2.000" OD x 0.134" THK	1/2" SOLID ROD	1/2" SOLID ROD	6 BAYS @ 1'-5 1/4"
20' TO 30'	1810 S-M	2.000" OD x 0.134" THK	1/2" SOLID ROD	1/2" SOLID ROD	6 BAYS @ 1'-5 1/4"
10' TO 20'	1810 S-M	2.000" OD x 0.134" THK	1/2" SOLID ROD	1/2" SOLID ROD	6 BAYS @ 1'-5 1/4"
0' TO 10'	1810 S-B	2.000" OD x 0.134" THK	1/2" SOLID ROD	1/2" SOLID ROD	6 BAYS @ 1'-5 1/4"

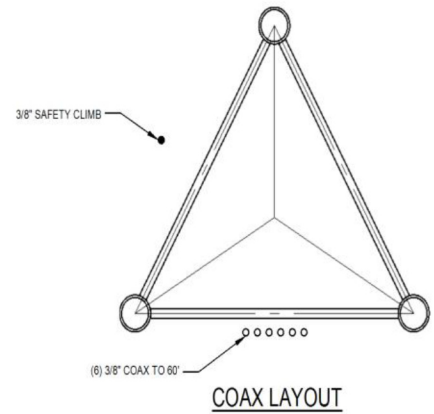

WIND DESIGN DATA	
REFERENCE STANDARD	ANSI/TIA-222-H-2017
CODE	2018 IBC
BASIC WIND SPEED (MPH)	105
ICE THICKNESS (IN)	2.0
ICE WIND SPEED (MPH)	40
SERVICE WIND SPEED (MPH)	60
RISK CATEGORY	II
EXPOSURE CATEGORY	C
MAXIMUM TOPOGRAPHIC FACTOR, $K_{ZT}$	1.0
SEISMIC DESIGN DATA	
RISK CATEGORY	II
SITE CLASS	D
$S_S$	2.5
$S_1$	1.0

THE SUITABILITY OF THE TABULATED TOWER DESIGN CRITERIA FOR A SPECIFIC APPLICATION MUST BE VERIFIED PRIOR TO INSTALLATION BY THE PURCHASER BASED ON SITE-SPECIFIC DATA AND INTENDED USE OF THE STRUCTURE.

FACTORED BASE REACTIONS	
SHEAR (KIPS)	1.2
AXIAL (KIPS)	1.3
MOMENT (KIP-FT)	44.3

FACTORED LEG REACTIONS	
MAX COMPRESSION (KIPS)	34.5
COMPRESSION SHEAR (KIPS)	0.3
MAX TENSION (KIPS)	33.7
TENSION SHEAR (KIPS)	0.5

- ALL STEEL SHALL CONFORM TO THE FOLLOWING:
- A. PIPE LEGS: ASTM A500 GR C (50 KSI YIELD POINT MATERIAL)
  - B. ALL OTHER STEEL SHAPES AND PLATES: ASTM A572 GR 50 (50 KSI YIELD POINT MATERIAL)
  - C. STRUCTURAL BOLTS: ASTM A325 TYPE 1 WITH ASTM A563 GRADE DH NUTS
  - D. ANCHOR RODS: ASTM A193 GR B7 WITH ASTM A194 GRADE 2H NUTS

CPT-6018-FS			
60' FREE STANDING 18" TRIANGULAR STEEL TOWER			
SIZE B	DATE: 16-12-2024	DWG NO 1306	SHT. # 1

**GENERAL NOTES:**

1. THE CONTRACTOR IS RESPONSIBLE FOR LOCATING ANY UTILITIES THAT MAY BE ENCOUNTERED PRIOR TO EXCAVATION.
2. THE CONTRACTOR MUST BE EXPERIENCED IN THE PERFORMANCE OF WORK SIMILAR TO THAT DESCRIBED ON THESE DRAWINGS. BY ACCEPTANCE OF THIS PROJECT, THE CONTRACTOR IS ATTESTING THAT HE DOES HAVE SUFFICIENT EXPERIENCE AND ABILITY, THAT HE IS KNOWLEDGEABLE OF THE WORK TO BE PERFORMED AND THAT HE IS PROPERLY LICENSED TO DO THIS WORK IN THE JURISDICTION IN WHICH THE WORK IS TO BE PERFORMED.
3. SPECIAL INSPECTIONS SHALL BE PERFORMED IN ACCORDANCE WITH THE SPECIAL INSPECTION TABLES ON THIS SHEET.

**GEOTECHNICAL AND SOIL NOTES:**

1. THIS FOUNDATION DESIGN WAS BASED ON THE "ANNEX F: PRESUMPTIVE SOIL PARAMETERS" OF THE TIA-H STANDARD AS FOLLOWS:
  - A. NOMINAL ULTIMATE NET BEARING STRENGTH = 4000 PSF
  - B. ANGLE OF INTERNAL FRICTION = 30°
  - C. EFFECTIVE UNIT WEIGHT OF SOIL = 100 PCF
  - D. GROUNDWATER BELOW THE FOUNDATION
2. THE MATERIAL BELOW THE FOUNDATION SHALL BE VERIFIED BY A GEOTECHNICAL ENGINEER TO ACHIEVE ADEQUATE DESIGN CAPACITY. IF THE SOIL CONDITIONS DO NOT MEET THE PRESUMPTIVE SOIL PARAMETERS, PAUL J. FORD AND COMPANY SHALL BE CONTACTED IMMEDIATELY TO DETERMINE THE SIGNIFICANCE IN DEVIATION.

**CONCRETE NOTES:**

1. ALL CONCRETE WORK SHALL BE IN ACCORDANCE WITH THE "BUILDING CODE REQUIREMENTS FOR STRUCTURAL CONCRETE" ACI 318 (LATEST EDITION) AND "SPECIFICATIONS FOR STRUCTURAL CONCRETE" ACI 301 (LATEST EDITION).
2. CONCRETE SHALL CONFORM TO THE FOLLOWING REQUIREMENTS:
  - A. 28 DAY COMPRESSIVE STRENGTH: 4500 PSI (MINIMUM)
  - B. WATER CEMENT RATIO: 0.45 (MAXIMUM). CEMENT SHALL CONFORM TO ASTM C150. WATER SHALL BE CLEAN AND FREE FROM OILS, ACIDS, ALKALIS, AND ORGANIC MATERIALS. NO ADDITIONAL WATER SHALL BE ADDED TO THE CONCRETE AT THE JOB SITE.
  - C. DENSITY: 150 PCF (MINIMUM)
  - D. MAX COARSE AGGREGATE SIZE SHALL BE 1"
  - E. AIR ENTRAINMENT: 6% ± 1.5%
  - F. CONCRETE SHALL BE PROPORTIONED AND PRODUCED TO HAVE A SLUMP OF NOT MORE THAN 4" ± 1" OR 8" ± 1" FOR CONCRETE WITH VERIFIED SLUMP OF 2" TO 4" BEFORE ADDING HIGH-RANGE WATER-REDUCING ADMIXTURE OR PLASTICIZING ADMIXTURE.
  - G. FLY ASH OR OTHER POZZOLANS CONFORMING TO ASTM C618 SHALL NOT EXCEED 25% OF CEMENTITIOUS MATERIALS BY WEIGHT.
  - H. ADMIXTURES SHALL NOT CONTAIN CHLORIDE IONS UNLESS APPROVED BY THE ENGINEER OF RECORD.
3. WATER SHALL BE REMOVED FROM OPEN EXCAVATION PRIOR TO CONCRETE PLACEMENT. WATER MUST NOT BE ALLOWED TO WASH THE CEMENT FROM THE AGGREGATE.
4. CONTRACTOR SHALL VERIFY LOCATIONS OF ALL OPENINGS, SLEEVES, ANCHOR RODS, INSERTS, ETC., AS REQUIRED BEFORE CONCRETE IS PLACED.

5. CONCRETE SHALL BE POURED MONOLITHICALLY.
6. CONCRETE SHALL BE PLACED WITHIN 24 HOURS OF EXCAVATION INSPECTIONS. THE CONTRACTOR SHALL BE RESPONSIBLE FOR PROTECTING EXPOSED EXCAVATIONS PRIOR TO CONCRETE PLACEMENT.
7. THE TOP OF THE CONCRETE SHALL BE SLOPED (APPROXIMATELY 1/8" PER FOOT) TO DRAIN. THE EXPOSED EDGES OF CONCRETE SHALL BE CHAMFERED 3/4" BY 3/4" MINIMUM.
8. HOT WEATHER CONCRETE PLACEMENT SHALL COMPLY WITH ACI 305R. COLD WEATHER CONCRETE PLACEMENT SHALL COMPLY WITH ACI 306.1.
9. ALL CONCRETE SHALL BE CONSOLIDATED BY MECHANICAL VIBRATION EQUIPMENT. VIBRATORS SHALL NOT BE USED TO TRANSPORT CONCRETE.
10. THE CONTRACTOR SHALL ASSIST TESTING AGENCY IN MAKING A MINIMUM OF (2) TEST CYLINDERS PER TEST. CONCRETE TESTS SHALL BE CONDUCTED FROM A MINIMUM OF (5) RANDOMLY SELECTED TRUCKLOADS PER DAY. IF FEWER THAN (5) TRUCKLOADS OF CONCRETE ARE USED, A TEST SHALL BE CONDUCTED FROM EACH TRUCKLOAD. TESTING AGENCY SHALL PERFORM STRENGTH TESTS IN ACCORDANCE WITH ACI 318.

**CONCRETE REINFORCING STEEL NOTES:**

1. ALL REINFORCING STEEL SHALL CONFORM TO ASTM A 615 GRADE 60, UNO.
2. MINIMUM CONCRETE COVER FOR REINFORCEMENT SHALL BE 3 INCHES, UNO.
3. PROVIDE CLASS "B" TENSION LAP SPLICE OR FULL MECHANICAL SPLICE IN ACCORDANCE WITH ACI 318 (LATEST EDITION) HORIZONTAL MAT REINFORCING STEEL.
4. REINFORCING STEEL SHALL BE DETAILED, FABRICATED, BENT AND PLACED IN ACCORDANCE WITH THE CRSI MANUAL OF STANDARD PRACTICE AND ACI 315 (LATEST EDITION).
5. CONTRACTOR SHALL PROVIDE SPACERS, CHAIRS, BOLSTERS, ETC., NECESSARY TO SUPPORT REINFORCING STEEL. CHAIRS WHICH BEAR ON EXPOSED CONCRETE SURFACES SHALL HAVE ENDS WHICH ARE PLASTIC TIPPED OR STAINLESS STEEL.
6. WELDING OF REINFORCING AND EMBEDMENTS IS PROHIBITED.

**GENERAL FOUNDATION NOTES:**

1. THE FOUNDATION DESIGN HAS BEEN DEVELOPED IN ACCORDANCE WITH GENERALLY ACCEPTED PROFESSIONAL ENGINEERING PRINCIPLES AND PRACTICES.
2. WORK SHALL BE IN ACCORDANCE WITH LOCAL CODES AND SAFETY REGULATIONS. THE FOUNDATION CONTRACTOR SHALL BE RESPONSIBLE FOR CONTACTING THE LOCAL BUILDING OFFICIALS FOR ANY INSPECTIONS THAT MAY BE REQUIRED.

TABLE 1705.3 REQUIRED SPECIAL INSPECTIONS AND TESTS OF CONCRETE CONSTRUCTION				
TYPE	CONTINUOUS SPECIAL INSPECTION	PERIODIC SPECIAL INSPECTION	REFERENCED STANDARD	IBC REFERENCE
1. INSPECT REINFORCEMENT AND VERIFY PLACEMENT	-	X	ACI 318 CH. 20, 25.2, 25.3, 26.8.1-26.8.3	1908.4
2. INSPECT ANCHORS CAST IN CONCRETE	-	X	ACI 318: 17.8.2	-
3. INSPECT ANCHORS POST-INSTALLED IN HARDENED CONCRETE MEMBERS. a. ADHESIVE ANCHORS INSTALLED IN HORIZONTALLY OR UPWARDLY INCLINED ORIENTATIONS TO RESIST SUSTAINED TENSION LOADS. b. MECHANICAL ANCHORS AND ADHESIVE ANCHORS NOT DEFINED IN 3.a.	-	-	ACI 318: 17.8.2.4 ACI 318: 17.8.2	-
4. VERIFY USE OF REQUIRED DESIGN MIX	-	X	ACI 318: CH. 19, 26.4.3, 26.4.4	1904.1, 1904.2, 1908.2, 1908.3
5. PRIOR TO CONCRETE PLACEMENT, FABRICATE SPECIMENS FOR STRENGTH TESTS, PERFORM SLUMP AND AIR CONTENT TESTS, AND DETERMINE THE TEMPERATURE OF THE CONCRETE	X	-	ASTM C172 ASTM C31 ACI 318: 26.5, 26.12	1908.10
6. INSPECT CONCRETE PLACEMENT FOR PROPER APPLICATION TECHNIQUES.	X	-	ACI 318: 26.5	1908.6, 1908.7, 1908.8
7. VERIFY MAINTENANCE OF SPECIFIED CURING TEMPERATURE AND TECHNIQUES.	-	X	ACI 318: 26.5.3-26.5.5	1908.9
8. INSPECT FORMWORK FOR SHAPE, LOCATION AND DIMENSIONS OF THE CONCRETE MEMBER BEING FORMED	-	X	ACI 318: 26.11.1.2(b)	-

TABLE 1705.6 REQUIRED SPECIAL INSPECTIONS AND TESTS OF SOILS		
TYPE	CONTINUOUS SPECIAL INSPECTION	PERIODIC SPECIAL INSPECTION
1. VERIFY MATERIALS BELOW SHALLOW FOUNDATIONS ARE ADEQUATE TO ACHIEVE THE DESIGN BEARING CAPACITY	-	X
2. VERIFY EXCAVATIONS ARE EXTENDED TO PROPER DEPTH AND HAVE REACHED PROPER MATERIAL	-	X
3. PERFORM CLASSIFICATION AND TESTING OF COMPACTED FILL MATERIALS	-	-
4. VERIFY USE OF PROPER MATERIALS, DENSITIES AND LIFT THICKNESSES DURING PLACEMENT AND COMPACTION OF COMPACTED FILL	-	-
5. PRIOR TO PLACEMENT OF COMPACTED FILL, INSPECT SUBGRADE AND VERIFY THAT SITE HAS BEEN PREPARED PROPERLY	-	-

**CPT-6018-FS**

60' FREE STANDING  
18" TRIANGULAR STEEL TOWER

SIZE	DATE:	DWG NO	SHT. #
B	16-12-2024	1306	2



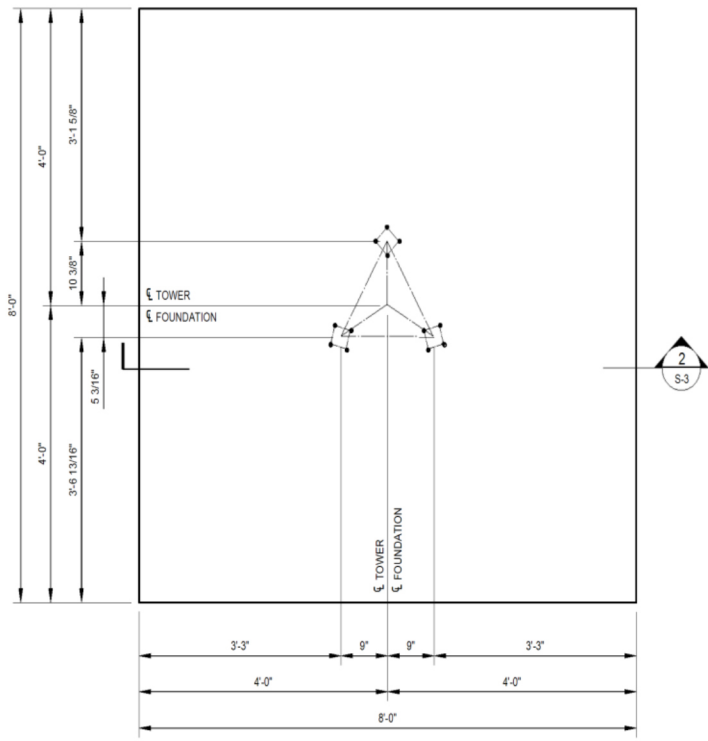

FOUNDATION PLAN 1 S-3

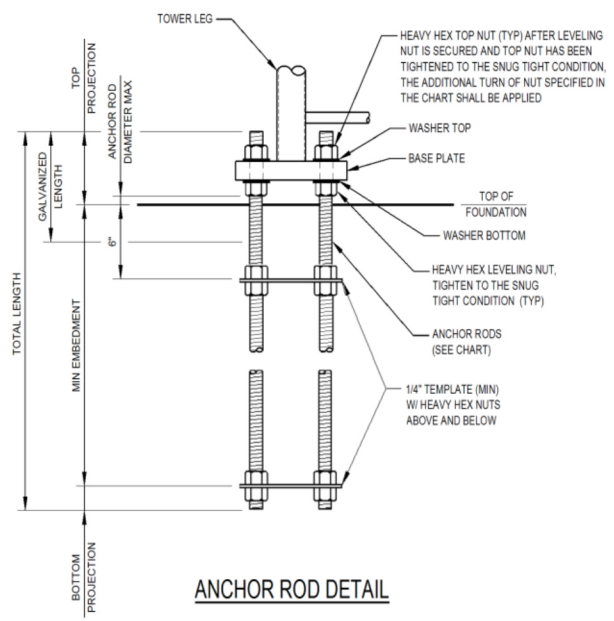

ANCHOR ROD DETAIL

ANCHOR ROD						
ANCHOR ROD QTY/SIZE	TOTAL LENGTH	MIN EMBEDMENT	TOP PROJECTION	GALVANIZED LENGTH	BOTTOM PROJECTION	ADDITIONAL TURN OF NUT
(4) 1/2"	2'-2"	1'-8"	0'-4"	1'-0"	0'-2"	1/3

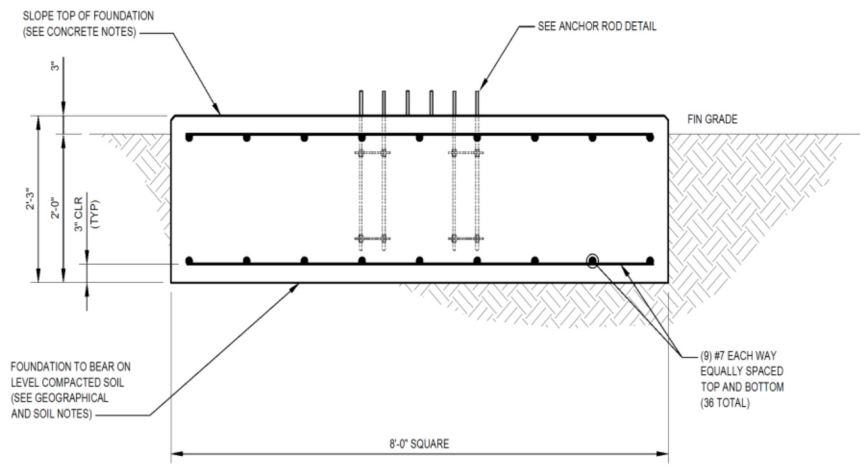

FOUNDATION ELEVATION 2 S-3

CPT-6018-FS			
60' FREE STANDING 18" TRIANGULAR STEEL TOWER			
SIZE B	DATE: 16-12-2024	DWG NO 1306	SHT. # 3